

Influence of Nano Phase Change Materials on the Desalination Performance of Double Slope Solar Still

Sasilatha T

Professor & Dean, Department of Electrical and Electronics Engineering,
AMET Deemed to be University, Chennai, India

Elavarasi R

Assistant Professor, Department of Electrical and Electronics Engineering,
AMET Deemed to be University, Chennai, India

Karthikeyan V

Professor, Department of Electrical and Electronics Engineering,
AMET Deemed to be University, Chennai, India

Abstract

Solar still is the ancient low cost device to distillate the saline water. Paraffin is a kind of phase change material which has a thermal storage characteristic and it can absorb and release a large amount of latent heat during the phase transition process. Ethylene Glycol was used as a PCM to study the thermal characteristics of water and absorption rate. A Nano phase change material plays a vital role in solar energy conversion and is used to enhance the thermal conductivity behavior on thermal energy storage systems. Materials at the nanoscale have a larger surface area and it has higher thermal properties than the macro particles. Incorporating NPCM into basin material helps to improve the productivity and the evaporation rate. The performance of the single basin double slope solar still was higher than the single slope solar still. Despite significant efforts, there are some challenges, such as the thermo physical properties of basin material, flow rate, insulation material and thickness that must be overcome in order for this technique to be useful in practice. In this paper, a detailed comparison of the various solar stills, designs, fabrications and water production analyses are discussed. Hence it is confirmed that NPCM has a higher potential than PCM for saline water desalination processes. This study confirmed that the Paraffin composites are stable up to 160°C and it increases the efficiency due to increased thermal properties of NPCM.

Keywords: Solar Energy, Phase-change materials; Nano materials, Double slope Solar still, Desalination

1. Introduction

Saline water desalination is one of the major requirement tools for society and the environment. There are many desalination techniques available for purifying brackish water, but they are economically high and not portable for all the climatic conditions. The majority of seawater desalination systems rely on thermal energy storage technologies and solar energy. It was widely used because of its high profitability. Desalination is a popular method in nations with limited freshwater resources. Many researches state that pure water imbalance is a unique problem to human life. To overcome scarcity of pure water, various desalination technologies are used. Solar stills stand out among the various water desalination technologies because of their simplicity, convenience and climatic conditions. The key attribute of PCM, its latent heat storage made it useful in heating and cooling a number of applications, including solar stills, heat pump systems, and solar power plant applications. Many factors are affecting the water purification; energy and cost are the important factors for all the process. Solar distillation is a cost-effective method for producing pure water by consuming the solar energy [1]. This necessitates an energy input, which can be from heat, electricity or solar radiation. To meet this demand, desalination technology is more widely used. This energy is directly employed to evaporate water inside a device; for example, several types of stills are used to desalinate saltwater and there are many different types of desalination processes accessible in water purification.

One of the inventions in the Thermal energy storage systems (TES) in phase change material, which has demonstrated thermal physical qualities in a variety of climatic settings. The phase change materials are used to store heat during the day and can be utilized at night. Thermal conductivity of phase change material helps to increase the production rate. Paraffin wax and fatty acids are the higher thermal conductive PCMs. Solar energy promotes freshwater evaporation in solar distillation systems; it gives a high percentage of pure water with a large concentration than the initial brine water. The evaporated brine is cooled to produce distilled water. The solar water desalination system is functioned by simple concept of evaporation and condensation through the transmission of sunlight via the transparent cover of the Solar still. For solar desalination applications, PCM and nanocomposites are attractive materials [2-4]. The energy is stored through phase shift of the storage medium, such as solid to solid, liquid to solid, or gas to liquid, in phase change energy materials. It has a sensible heat property that displays the temperature difference between the charging and discharging steps. Many studies [2-4] have shown that adding nanoparticles with PCM improves the still's productivity and efficiency. It shows better performance in the Thermal energy storage systems. Many researchers pointed out that phase change materials of Paraffin could play a vital role in heat storage capacity and thermal conductivity of solar still applications. [8]. They claimed that these materials suspended in the Water basin could improve the thermal conductivity. The average amount of these suspended materials is less than 40%. Since then, a variety of PCM

materials have been tested in numerous applications, including the solar still. Such PCMs are designed to improve heat transfer conditions. Such compounds are intended to improve heat transfer conditions. As a result, PCM should have greater thermal conductivity, better stability, and superior rheological qualities. Thermal characteristics of the Paraffin can be tailored to improve the SS's efficiency by altering the thermal characteristic of heat transfer co efficient and thermal conductivity.

In this paper we discuss the solar still mechanism and techniques to improve the solar still productivity. In this paper, we mentioned the advantages of using paraffin material as a NPCM. Adding a NPCM is a novel way for improving the material's thermal properties. It demonstrates a higher level of performance in thermal energy storage systems. Phase change materials have been discussed in a number of articles as having the potential to improve heat transfer and thermal storage systems in solar still applications.

2. Solar Energy and its Applications in Solar Still

Since many energy storage systems are available based on solar energy, energy storage serves a crucial role in preserving available energy and enhancing its utilization. Because the world's population and industry are rapidly expanding, the need for energy is a concern for future generations. To replace conventional energy systems, there is an alternate option of using solar energy systems, which are readily available and *cost-free*. However, considering solar energy is only available during the day, research has concentrated on phase change materials that store heat during the day and then release it at night. *Water* purification process can be possible by the solar distillation method. There are many different types of solar systems mostly used based on the simplicity and efficiency of water production. Mainly solar stills are classified by active type and passive. The qualities and functionalities of these solar stills are used to classify them. Recent studies have discovered that the inclination angles of the slope, the depth of the basin, materials, and solar radiation are some of the primary influencing elements of solar water productivity [10]. The key factor is the temperature difference between the water in the solar still basin and the temperature of the inner side of the glass. The temperature difference between the water in the solar still basin and the temperature of the inner side of the glass is the most important component in increasing the efficiency of water production. Solar stills that are active produce more energy than those that are inactive. The internal air circulation has been slightly increased to increase the temperature difference between the glass and basin water. It improves heat transfer between the basin medium and the water cover. The rate of condensation increases as the inner glass surface cools. There are also a number of minor tweaks that help to improve their output in terms of meteorological parameters and design, such as the usage of some tweaks on the interior and external sides of the solar water basin. The better alternative for improving solar desalination is to use nano phase change materials. The primary goal of Paraffin phase change material is to establish a well-defined PCM

fusion for enhanced thermos-physical properties. The paraffin can be dispersed in the saline water or the synthesized PCM can be suspended in the water basin to create effective solar still. Thus, in PCM, the unique physicochemical properties of paraffin provide greater heat conductivity and rheological properties.

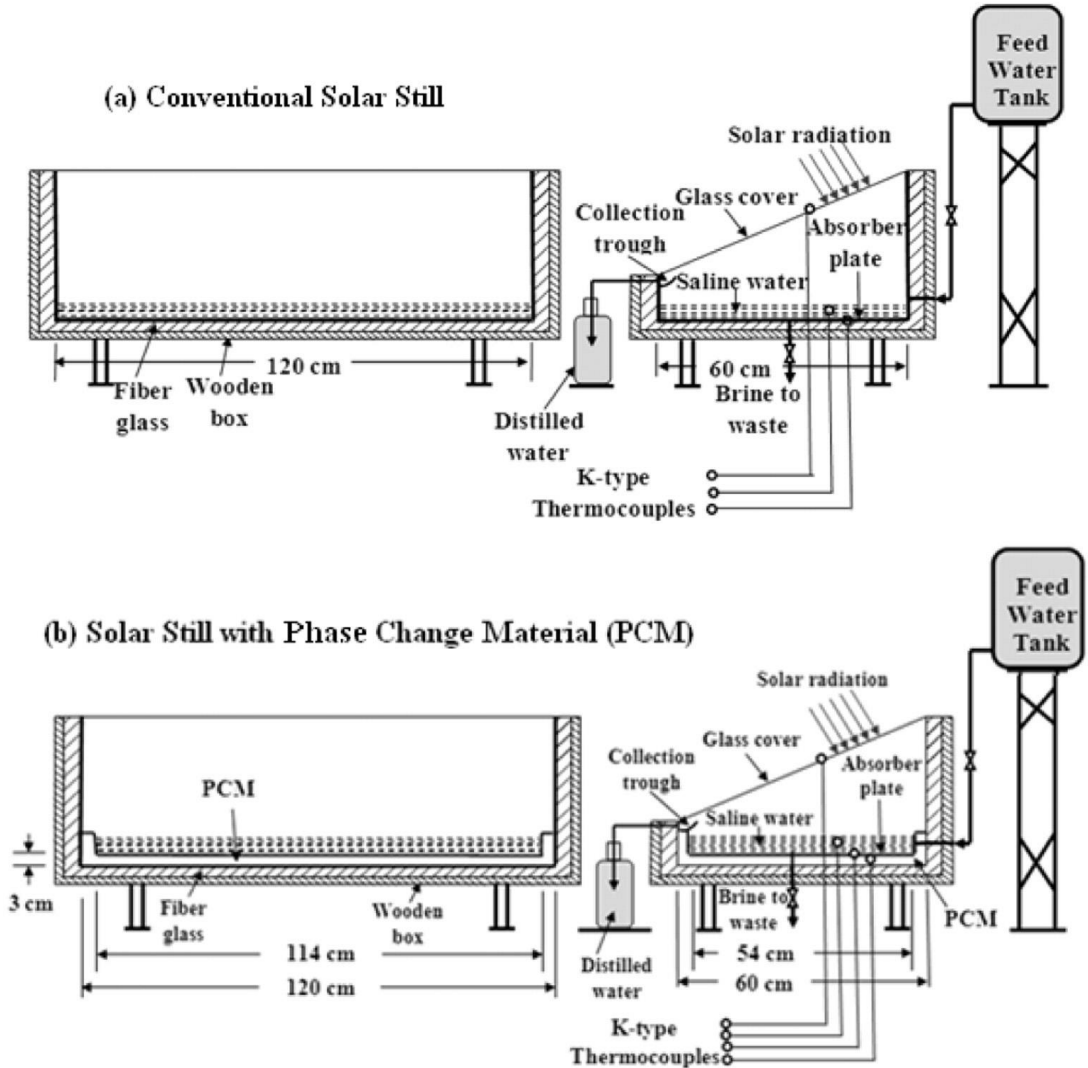

Figure 1. Different types of Solar still

2.1 Working Mechanism of Solar Still

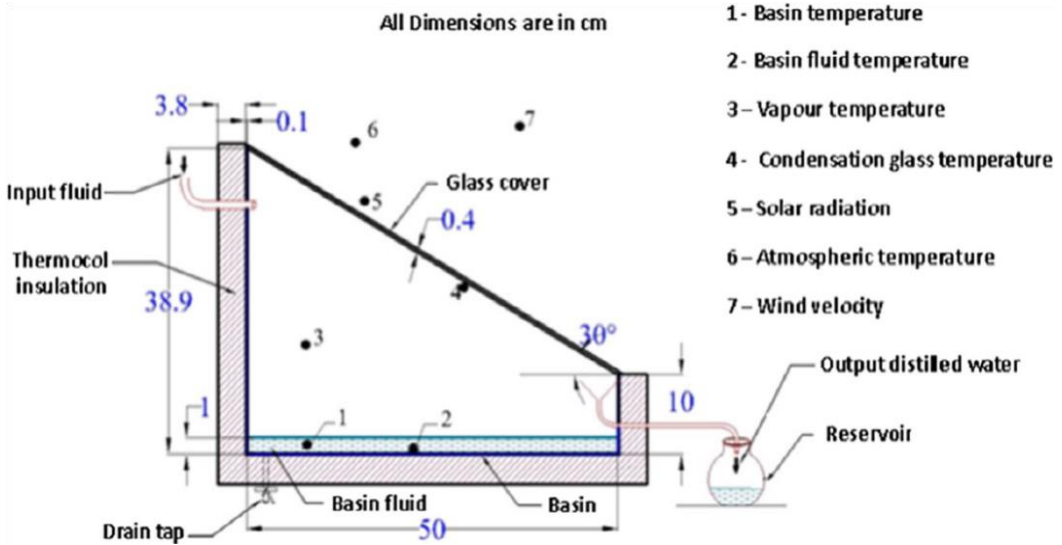

Figure.2 Mechanism of Solar still

The fresh water is distilled using a simple heat transfer mechanism in the solar still, which works on the principle of evaporation and condensation. Figure 1 depicts a schematic design of the solar still's concept and operation. The two forms of solar stills are active and passive and both rely on the evaporation and condensation processes. The basin, slope with glass cover and storage tank make up the majority of the solar still. The basin's surface is filled with saline water, which is heated by solar radiation and evaporates. The evaporating water condenses through the glass cover and the distillate collector subsequently collects the flow of condensed water. There are various sorts of ways that help to boost the productivity of water, such as using active components, external motors, pumps, fans, and absorption materials. Basin temperature and condensation temperature are the most important factors for solar water desalination [12]. Many studies have already been conducted on the use of sponge cubes, absorption materials, wick, black paints, fins, insulation, condenser and evacuation tubes in the modification of solar stills.

2.2 Improvement techniques of solar still by using Phase Change Materials:

The still output is inversely proportional to the depth of the water. Many studies have already concluded that the solar still basin's enormous surface area leads to high-efficiency water production. This method aids in increasing the rate of evaporation and lowering the volume ratio of the basin's surface. Organic PCM such as paraffin and fatty acids are well known, but inorganic phase change materials such as hydrated salts are the most common. The melting temperature of all phase change materials varies depending on the application. PCM are frequently employed in the energy

sector. The melting temperature of all phase change materials varies depending on the application. The phase change material is an unavoidable enhancing medium for solar still applications and organic PCM is the most widely used PCM in recent publications [14].

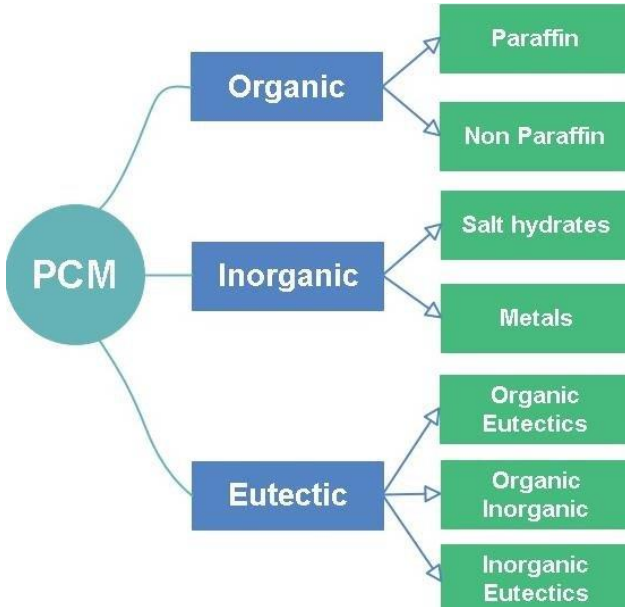

Figure 3. Classifications of Phase Change Materials

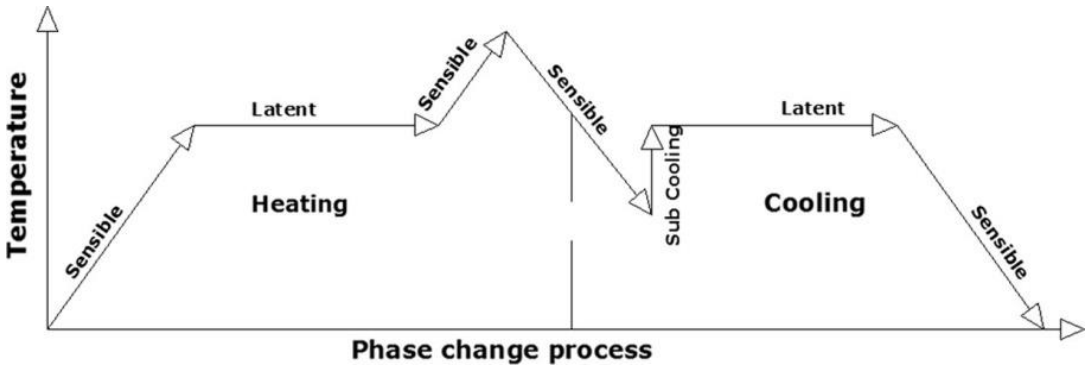

Figure 4. Schematic diagram of Phase change Process

PCM has a greater thermal conductivity property, allowing it to absorb and release heat during the phase shift process. During the transition, the temperature of these materials remains constant. During the transition of the heating process, the temperature of these materials remains constant. The melting point of PCM should be above 90°C in refrigeration applications and below 15°C in an air conditioning

applications. In comparison to sensible heat storage systems, latent heat thermal storage provides better charging and discharging qualities. It has a higher energy storage capacity and fusion heat. The most commonly used materials are organic and inorganic PCMs. For their properties of latent heat and high thermal conductivity, phase transition materials are commonly used in thermal storage applications. This type of material is referred to as latent heat storage material because of its consistent thermal conductivity. In the PCM, latent heat storage is essential; latent heat is the heat absorbed or released by the thermodynamic system. Latent heat of fusion is the latent heat associated with phase shifts in a thermodynamic system. Natural PCM (paraffin, unsaturated fats) and inorganic PCM (metallic salts) are the two types of PCM.

Table 1: Performance of Solar stills with Nano PCM

Author	Type of PCM	Type of Nanoparticles(NPs)	Size of NPs	Productivity
Kumeresan et al,	Paraffin	MWCNT	30-50 nm	3.56
yuvari et al,	1-Octadecanol	Graphene	NA	4.04
Teng and Yu	Paraffin	Al ₂ O ₃ and SiO ₂	20-40 nm	3.76
Ji et al,	Palmitic acid	MWCNT	25-50 nm	5.2
Li	Paraffin	Nano-graphite (NG)	35 nm	6.6

3. Paraffin and its Characteristics

Paraffin wax has high melting point in the desired operating temperature range. It melts constantly and freezes without much super-cooling. These features enable paraffin wax to find application in thermal energy storage systems. Natural PCMs are more artificially stable than inorganic Phase Change Materials, which soften uniformly without the need for super cooling. However, when compared to inorganic PCM, it has higher thermal conductivity. Most of the studies focused on improving PCM thermal characteristics like paraffin and fatty acids. In comparison to other PCM, paraffin is the most highly recommended material for latent heat thermal energy systems due to its poor thermal conductivity.

It was frequently utilized in TES applications because of its excellent properties, such as high sensible and latent heat, freezing and melting with low super cooling. They are also inexpensive; they are safe and paraffin is locally available different with a melting temperatures.

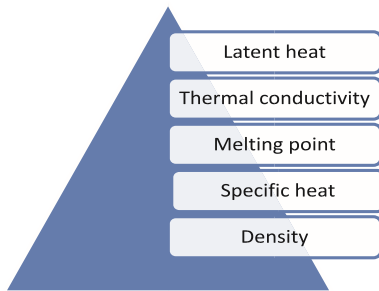

Figure 5(a). Important Properties of Phase Change Materials

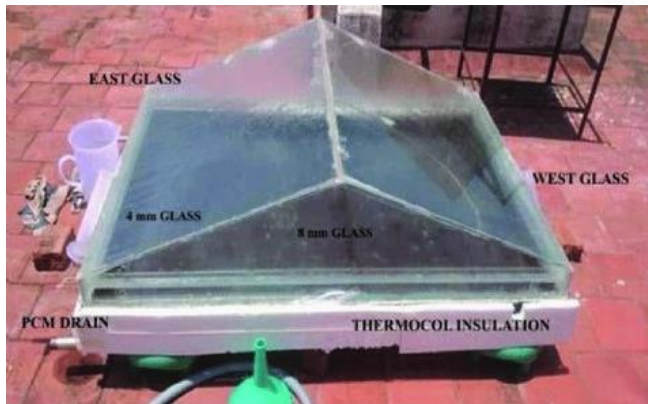
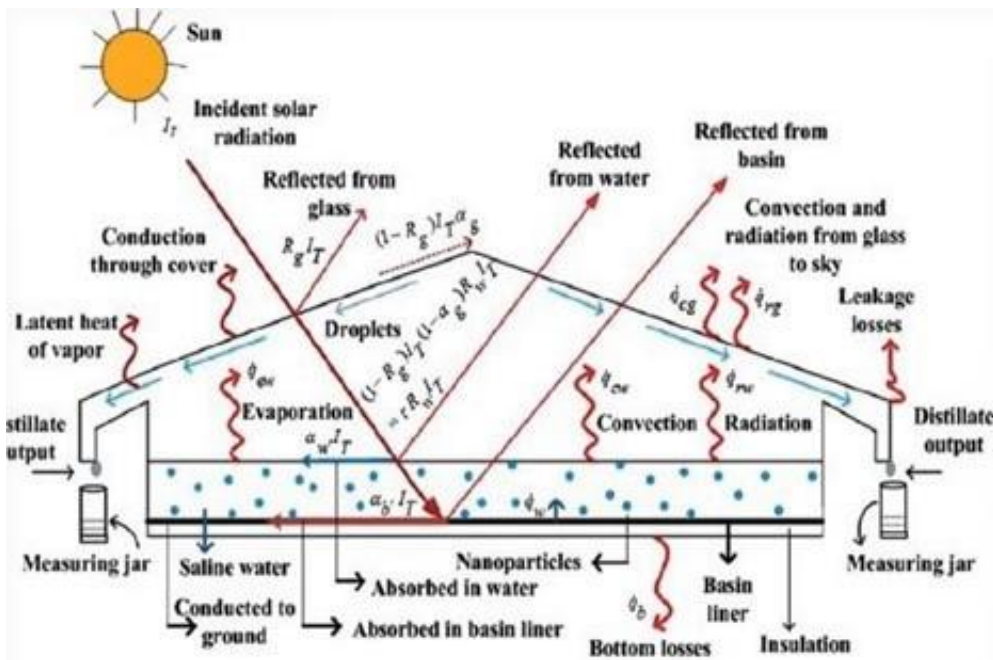

Figure 5(b). Mechanism of Double slope solar still

Table 2: Thermal Characteristics of paraffin

	Melting Temperature, °C	latent heat temperature, J/g	Freezing temperature °C	Freezing point of latent heat, J/g
Paraffin	51.6	181.11	52.4	-175.11
20 wt % paraffin with composite PCM	53.4	95.82	51.4	-92.15
40 wt % paraffin with composite PCM	52.8	105.73	52.1 7	-98.55
20wt % paraffin with composite PCM After preheating and cooling	52.8	91.65	51.23	-91.32
40 wt % paraffin with composite PCM After preheating and cooling	54.3	115.57	52.43	-97.90

Rayleigh and the Stefan numbers can be defined based on the temperature difference of PCM and the length of the solar still. The formulas are given below, [6]

$$Ra_f = \frac{g\rho_f^2 c_{\rho,f} \beta_f (T_h - T_c) H^3}{k_f \mu_f}$$

$$Ra_m = \frac{g\rho_f^2 c_{\rho,f} \beta_f (T_h - T_c) H^3}{k_m \mu_m}$$

$$Ste_f = \frac{c_{\rho,f} (T_h - T_c)}{h_{ls,f}}$$

$$Ste_m = \frac{c_{\rho,m} (T_h - T_c)}{h_{ls,m}}$$

The ρ and T are respectively thermal conductivity and temperature parameters,

Table 3. List of different passive solar stills with paraffin wax.

S. No	Authors	Types of Solar still	% increase in productivity

1	Ravishankar et al.,	Single basin and double slope	23.95%
2	Sathyamurthy et al.,	Single basin and triangular	99%
3	Sonawan et al.,	Single basin with single slope	61%
4	Yadav et al.,	Stepped with weir type	36.32%
5	Shalaby et al.,	Single basin and v-corrugated absorber plate	13%
6	Subramanian	Single basin with single slope	188%
7	Ashis Kumar et al.,	Single basin with dual slope solar still	64%
8	Avesahmad et al.,	Dual slope with single basin	26%

3.1 Mechanism of heat transfer in PCM:

The Phase Change Material is a latent heat energy storage material. While heating the PCM, the heat is initially stored as a sensible heat within the PCM until it reaches into melting point temperature. The form of sensible heat stores the heat when the PCM in melting point. During the daytime the solar radiation is high, so the PCM absorbs the thermal energy in the PCM and it releases at the night time when the solar radiation is entirely low. The amount of solar energy is stored in the basins absorber plate is determines the performance of solar still. The temperature difference is drawn in the below diagram. It shows the PCM temperature and thermal conductivity, melting point, specific heat and density. The solar still performance is relying on the basin water temperature and the glass temperature in the solar still over the time. The water basin temperature for the solar still PCM is around 81°C and glass temperature in the range of 21°C to 80°C.

Effects on latent heat capacity:

The phenomenon of how paraffin alters the latent heat capacity of thermal storage is difficult to attribute. In this section, we will look at how the physical and surface features of PCM can affect the storage of latent heat storage capacity. Several researchers have undertaken numerous studies on solar stills, as well as paraffin and PCM, with a variety of favourable outcomes that have been used to improve their production. Incorporating heat conductive paraffin's into the solar still produces effective results, and adding the paraffin is being considered as a key element in solar still efficient improvement applications.

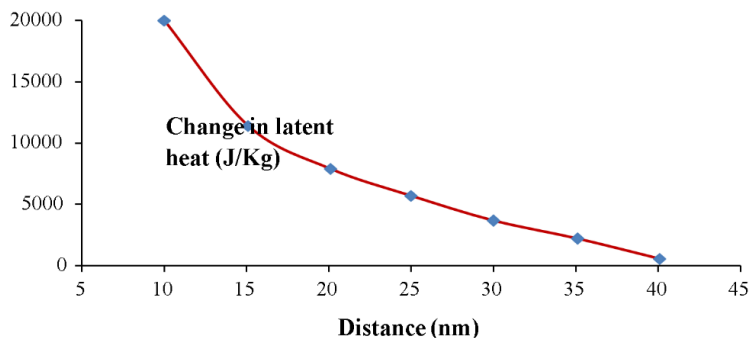

Figure 6. Change in Latent heat Capacity

3.2 Applications of Nano Enhanced Change Materials

The thermal conductivity of nano composite Phase Change Materials was shown to enhance when nano materials were dispersed in Phase change materials. Various nanoparticles, as shown in the diagram, contribute to improve the properties of TES. They demonstrated that the heat transfer effect in the surface medium has increased, as well as examining paraffin melting ability with nanoparticles. At the pipeline's entrance, a check valve is installed. To control the saline water flow rate, a check valve is installed at the pipeline's entry. It is positioned within the basin still, which is built of a 1.5 mm thick galvanized iron sheet measuring 0.5 m x 1.4 m. To maximize solar radiation absorption, the absorber surface is painted black. Nanocomposites phase change materials were prepared using various copper nanoparticles and carbon nanotubes, and experimental results showed that Nano PCM composites had better thermos-physical properties than those without Nano PCM. Previously, many studies on nano particle mixed organic materials were conducted instead of inorganic nanoparticles.



Preparation of nano Phase change material using paraffin and ZnO Nanoparticles

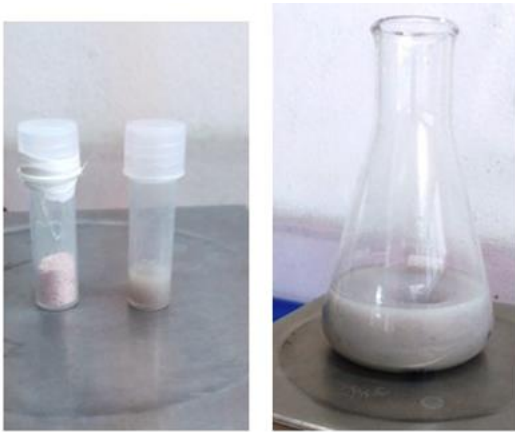

Figure 7. Preparation of Nano PCM.

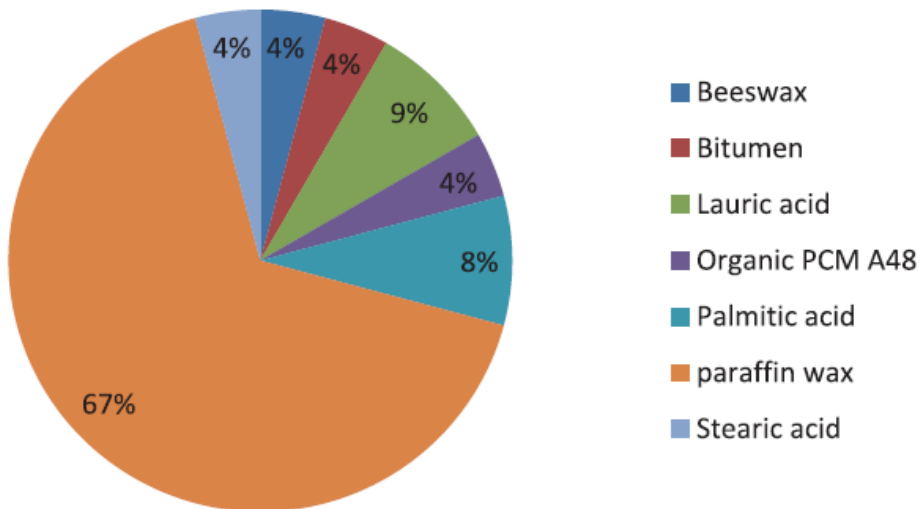

Figure 8. Different types of PCM used for solar still Applications

4. Effects of using the Nano PCM in Solar still

The performance of the desalination unit is depending on the solar radiation and water temperature, glass cover temperature and the Phase change material. Performance of the desalination unit for different composite materials were shown in Figure.9. the time-to-time production was measured with and with PCM. As mentioned in the earlier day time production is higher than the nighttime production. The results are shown that the maximum of temperatures and productivity occur later

than the peak of solar radiation. This is because some of the heat from the sun is still stored as sensible and latent heat within the PCM, which requires large time and energy to raise the temperatures.

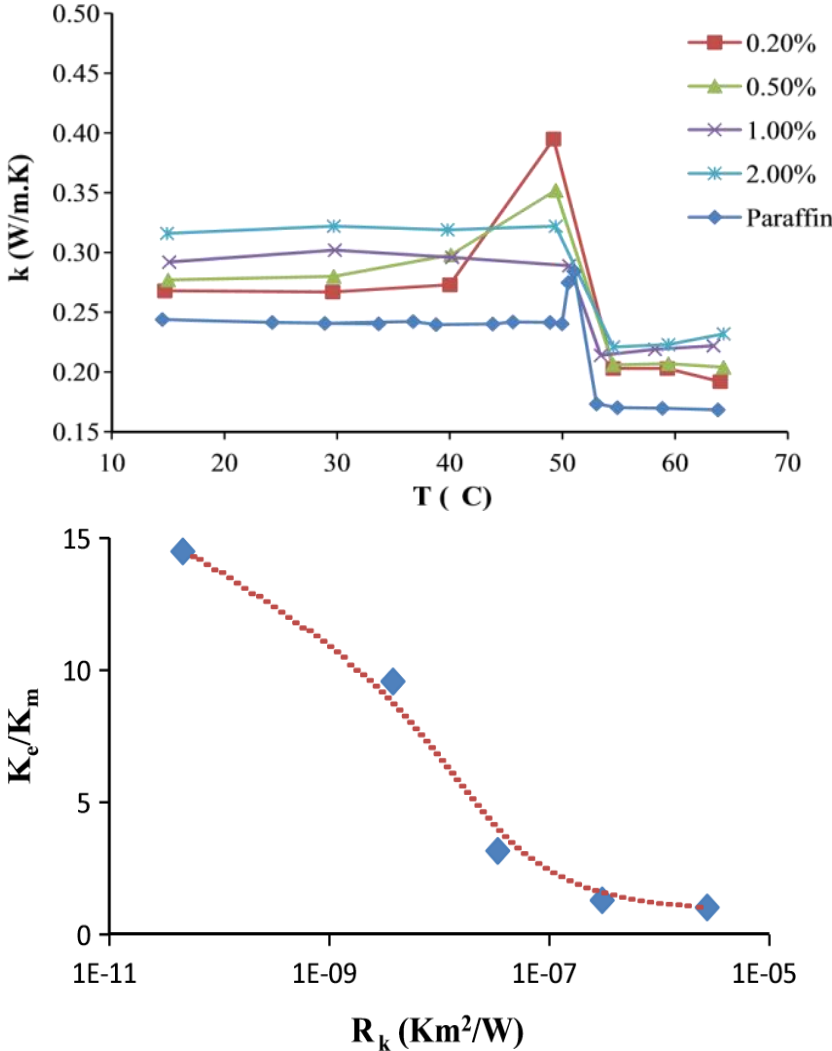

Figure 9. Paraffin enhanced solar systems

Conclusion

The thermal conductivity has played a major role in the thermal property of the PCM; paraffin has a comparatively low thermal conductivity than other PCM. The dispersion of the nano composite materials increased the thermal conductivity. The influence of PCM on the behavior of the solar still with PCM was explored theoretically by the nearest meteorological circumstances. The paraffin PCM has a large latent heat

capacity than other materials, and it is proven that paraffin materials can be used in the solar still for the better performance of solar still water purification. Moreover, from the studies we are confirmed that the Paraffin composites are stable up to 160°C. These materials being used for double slope solar still and it will increase the efficiency due to the increased thermal properties of Nano PCM.

References

- [1] Zhang L-Z, Li G-P. Energy and economic analysis of hollow fiber membrane-based desalination system driven by solar energy. *Desalination* 2017;404:200–14.
- [2] Chieruzzi, M., et al., Effect of nanoparticles on heat capacity of nanofluids based on molten salts as PCM for thermal energy storage. *Nanoscale research letters*, 2013. 8(1): p. 448.
- [3] A.E. Kabeel, M. Abdelgaied, Improving the performance of solar still by using PCM as a thermal storage medium under Egyptian condition, *Desalination* 383 (2016) 22-28.
- [4] Dimaano, M. N. R., and Watanabe, T. 2002. Performance investigation of lauric acid mixture as latent heat energy storage for a cooling system. *Solar Energy* 72(3):205.
- [5] Arunkumar, T., Vinothkumar, K., Ahsan, A., Jayaprakash, R., Kumar, S., 2012. Experimental study of various solar still designs. *ISRN Renewable Energy* 2012.
- [6] V.H. Crespi, L.X. Benedict, S.G. Louie, *Phys. Rev. B* 53 (1996) R13303.
- [7] . Novais, R. M.; Ascensão, G.; Seabra, M. P et al, Lightweight dense/porous PCM-ceramic tiles for indoor temperature control. *Energ Buildings* **2015**, *108*, 205-214.
- [8] D.D.W. Rufuss, S. Iniyan, L. Suganthi, P.A Davies, A comprehensive review of designs, performance and material advances of solar still, *Renew. Sust. Energ. Rev.* 63 (2016) 464-496.
- [9] Mauricio Terrones et al., Graphene and graphite nanoribbons: Morphology, properties, synthesis, defects and applications, *Nano Today* (2010) 5, 351—372.
- [10] Su, W., J. Darkwa et al, Review of solid– liquid phase change materials and their encapsulation technologies. *Renewable and Sustainable Energy Reviews*, 2015. 48(Supplement C): p. 373-391.
- [11] Saleel CA, Mujeebu MA, Algarni S. Coconut oil as phase change material to maintain thermal comfort in passenger vehicles. *J Therm Anal Calorim.* 2019;136(2):629–36.
- [12] Nasrin R, Alim M, Chamkha AJ. Effects of physical parameters on natural convection in a solar collector filled with nanofluid. *Heat Transf Asian Res.* 2013;42(1):73–88.

- [13] Kumar RA, Esakkimuthu G, Murugavel KK. Performance enhancement of a single basin single slope solar still using agitation effect and external condenser. *Desalination*.2016;399:198–202.
- [14] Suneesh P, Jayaprakash R, Arunkumar T, Denkenberger D. Effect of air flow on “V” type solar still with cotton gauze cooling. *Desalination*. 2014;337:1–5.
- [15] Chon CH, et al, Empirical correlation finding the role of temperature and particle size for nanofluid (Al₂O₃) thermal conductivity enhancement. *Applied Physics Letters*. 2005 Oct 10;87(15):153107.
- [16] Gong ZX et al, Enhancement of energy charge-discharge rates in composite slabs of different phase change materials. *International Journal of Heat and Mass Transfer*. 1996 Mar 1;39(4):725-33.
- [17] Choi SU, Zhang ZG, Yu W, Anomalous thermal conductivity enhancement in nanotube suspensions. *Applied physics letters*. 2001 Oct 1;79(14):2252-4.
- [18] Velmurugan V, Gopalakrishnan M, Raghu R, Srithar K. Single basin solar still with fin for enhancing productivity. *Energy Convers Manag*. 2008;49(10):2602–8.
- [19] S.Vidhya, T.Sasilatha, "Performance attack of blackhole attack detection scheme using MD5 algorithm in WSN, ICSSS, 51-54, 2014.